

Crooked Still Stage Layout

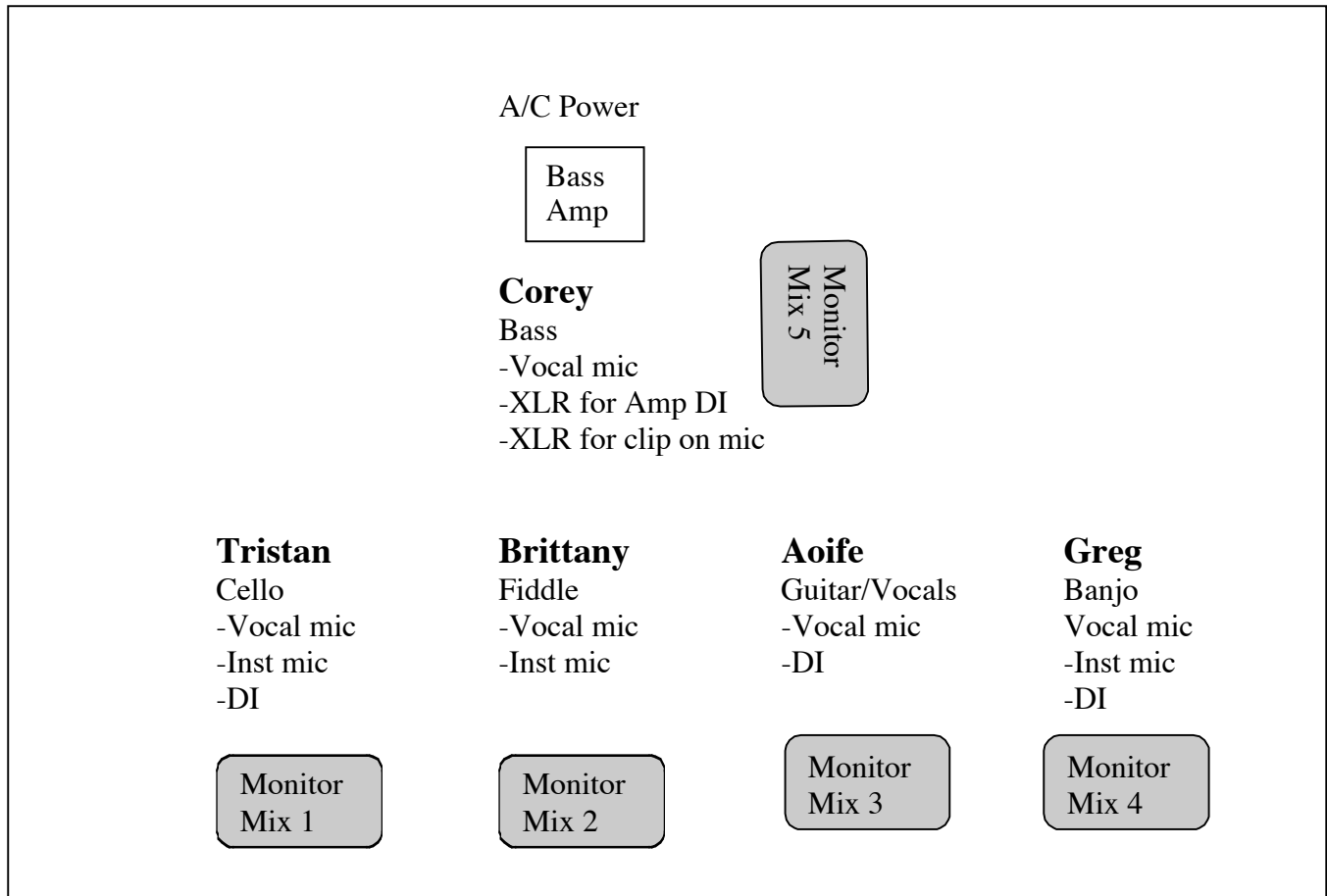

Audience

Channel Breakdown:

- 5 Vocal Mics (SM 58 or similar)
- 3 Instrument Mics (SM 57 or similar)
- 3 DI boxes
- 1 XLR cable for clip on bass mic
- 1 XLR cable bass amp DI

Equipment needed:

- 5 separate monitor mixes
- At least 13 inputs on mixing board.
- 9 boom stands for vocal/instrument mics
- 1 armless chair for cello
- 1 riser for cello
- rug for cello
- phantom power
- enough mics, cables and stands for everything above
- AC Power on stage
- 3 quarter inch instrument cables

We would like to be positioned as close to each other as possible on stage